



Assembly Instructions & Owners Manual

This pitching machine has been manufactured for years of use. However, proper care and maintenance must be provided to insure that you get the full potential of this pitching machine. Read the instructions thoroughly before putting this machine into use. Users must be 18 years old and must be properly trained.

Inspect all parts of the machine for any damage that may have occurred during shipping. Report any damage immediately. Save the cartons and packaging materials in case you have to return the machine for any reason.

Save this manual: Use it to instruct and train others to use the machine. Do not let anyone use the machine that has not been trained.





MOUND YETI™

ITEM	DESCRIPTION	QTY
A	Main Frame	1
B	Tripod Base	1
C	Legs	3
D	Rubber Feet	3
E	Knob Bolts	3
F	Pitching Wheel	1
G	Axle - set screw & key	1
H	Pinch Pad	1
I	Baseball Chute	1
J	Softball Chute	1
K	Motor with cord	1
L	Tilt Adjustment Handle	1
M	8mm Washer	6
N	8mm x 13mm Hex Bolt	4
O	Motor Controller & Housing	1
P	Speed Controller Adj Knob	1
Q	8mm Carriage Bolt	2
R	2.5mm Hex Key Wrench (not shown)	1
S	8mm Lock Washer	2
T	8mm Hex Nut	2

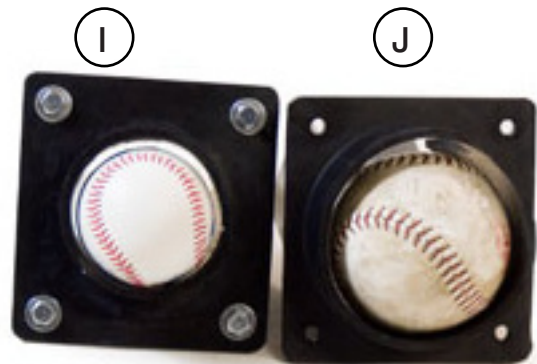
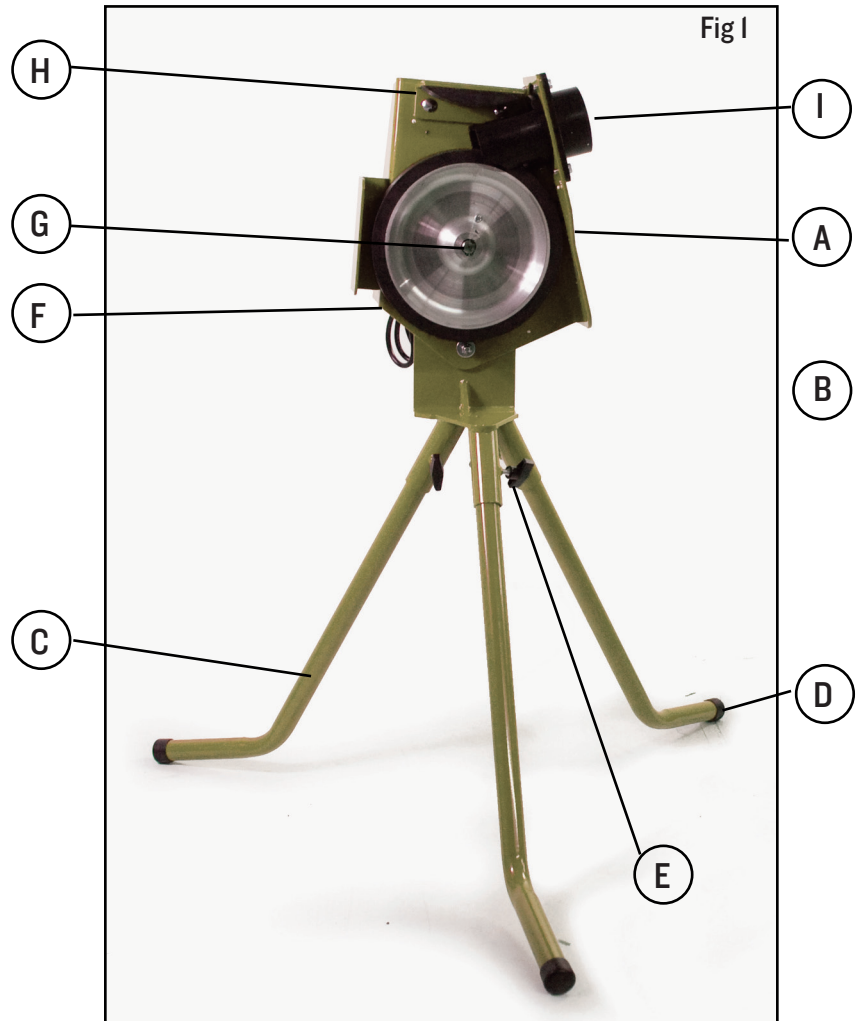



MOUND YETI™

ITEM	DESCRIPTION	QTY
A	Main Frame	1
B	Tripod Base	1
C	Legs	3
D	Rubber Feet	3
E	Knob Bolts	3
F	Pitching Wheel	1
G	Axle - set screw & key	1
H	Pinch Pad	1
I	Baseball Chute	1
J	Softball Chute	1
K	Motor with cord	1
L	Tilt Adjustment Handle	1
M	8mm Washer	6
N	8mm x 13mm Hex Bolt	4
O	Motor Controller & Housing	1
P	Speed Controller Adj Knob	1
Q	8mm Carriage Bolt	2
R	2.5mm Hex Key Wrench (not shown)	1
S	8mm Lock Washer	2
T	8mm Hex Nut	2

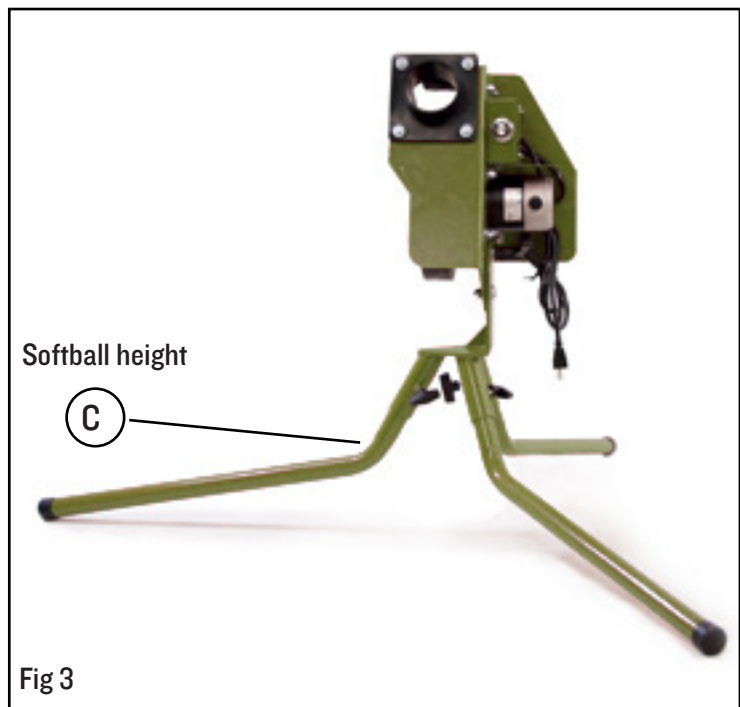
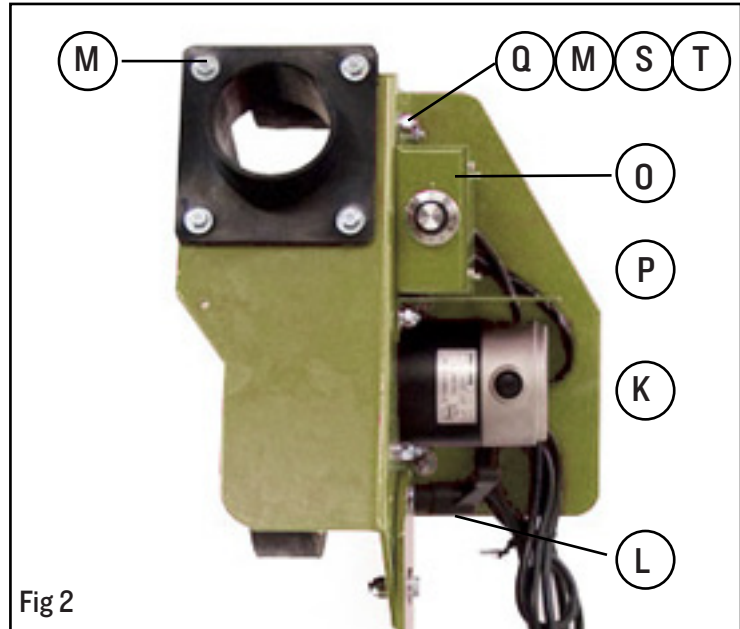



Step 1) Insert legs (C) into Tripod Base (B) and hand tighten Knob Bolts (E) See Figure 1 & 2

Note: The same set of legs is used for both baseball and softball. For softball, insert the short end of the legs into the base. For baseball, insert the long end.

Step 2) Two ball chutes are provided - a bigger one for softball (J) and a smaller one for baseball (I). Attach the appropriate chute using the supplied bolts (N) and washers (M). See figure 1 & 3

Step 3) Now make certain the Pinch Pad (H) is in the correct position for softball or baseball, whichever you decide to set up. The upper position is for softball and the lower position is for baseball. See figure 3 and PINCH PAD ADJUSTMENT.

PINCH PAD ADJUSTMENT

The term “PINCH” refers to the space between the pitching wheel and the pad above the wheel. The Yeti I is able to throw both baseballs and softballs, but adjustments must be made switching between the two. If you primarily use the machine for

STEP 1) Turn the machine off and unplug the electrical cord. To change from baseball setting to softball setting (the Yeti I arrives preset in the baseball position).

STEP 2) Note that there are four bolt holes for the pad - two down (baseball-default orientation) and two up (softball). Remove the two bolts on the pad frame (currently in the lower holes). Slide the pad upward to the topmost bolt holes and reinsert the bolts.

Retighten the bolts

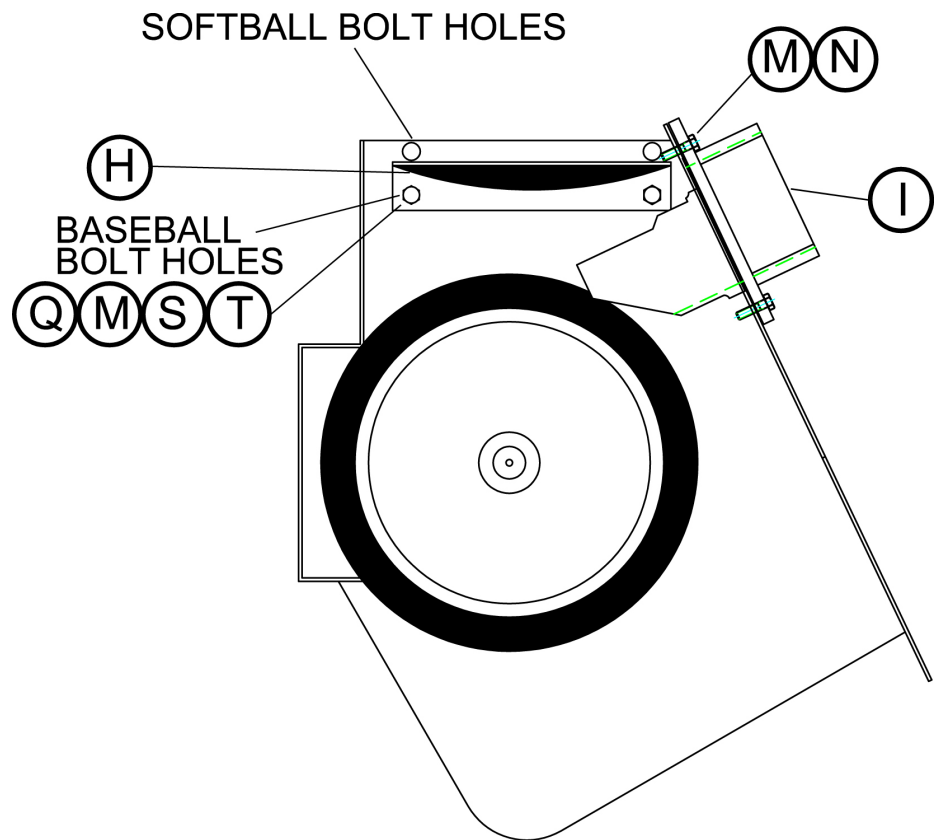



ELECTRICAL POWER REQUIREMENT

Your machine requires a standard 110 volt, AC power supply. For an alternate source, you may use a generator. Be sure the generator has an output of at least 1000 watts.

EXTENSION CORD

Use only a 3-wire cord that has a 3-prong plug and 3-pole receptacle that will accept the power cord plug on the machine. Use only an extension cord that is rated for outdoor use. It is important to use a cord with the proper wire gauge size. The longer the cord, the bigger the wire must be. (The smaller the gauge number, the larger the wire). Refer to the chart below for the proper size.

Length	Gauge of Wire
25 ft	16
50 ft	14
100 ft	12
150 ft	10
200 ft	8

Ground the Machine

Your machine is manufactured with a 3-prong grounding plug and must be plugged into an extension cord as detailed above. Proper grounding is essential to insure your safety should a malfunction occur. The unit must be connected to a GFCI outlet that meets all local and state codes. If you have any doubts about the electrical connections, contact a licensed electrician.

USING A GENERATOR

Start the generator

Plug the surge protector into the generator

Turn on pitching machine

CAUTION: ALWAYS USE A SURGE PROTECTOR WHEN USING A GENERATOR. POWER SURGES CAN DAMAGE THE SPEED CONTROLLERS



OPERATING THE PITCHING MACHINE

This machine was designed and developed to aid you in improving your batting skills. Hitting balls that are thrown too fast will not allow you to improve the mechanics of your swing. Remember, excessive speeds can be dangerous. See speed chart as a general guide. Different balls may go at a different rate of speed depending on the condition of the ball. For accurate speeds, use a radar gun.

SETTING UP THE MACHINE

Set the machine in the desired location. Place a protector screen in front of the machine. Batter and operator must wear a batting helmet. Be sure the path of the ball to the batter is clear. Operator must be aware of his surroundings at all times. Allow no one in front of the machine. Before allowing the batter in the batters box, throw some practice pitches until you have the speed you want and the trajectory of the ball is consistently being thrown into the strike zone. If the machine is moved for any reason, you must repeat this procedure.

OPERATING SPEEDS

Your Yeti-I has 10 basic settings. These settings control the RPM of the wheel and the speed of the pitch. While not 100% accurate, the following chart provides a guide to the relationship between the speed setting on the control knob and the pitch speed of the ball.

THE MOUND YETI IS NOT DESIGNED TO PITCH REAL BASEBALLS OF SOFTBALLS. USE BALLS DESIGNED FOR MACHINE USE.

SPEED SETTING	SPEED - BASEBALL MPH (APP)	SPEED - SOFTBALL MPH (APP)
1	0	0
2	0	0
3	0	0
4	15	15
5	22	21
6	32	26
7	36	32
8	48	47
9	55	50
10	60	55

BALL TYPES:

Real leather balls have raised seams as part of their construction. Raised seams increase the overall wear on the polyurethane wheels of the machine and will potentially shorten the life of the wheel - this is true of all pitching machines. Raised seams also increase the overall wear on the ball itself potentially reducing the lifespan of the ball. Dimpled balls, made of polyurethane, are specifically designed for high speed pitching machines. These balls offer weight and size matches to real baseballs and softballs but will last longer, create less wear on the machine, and cost less (usually) than real balls.



SAFETY INFORMATION

READ ALL INSTRUCTIONS AND WARNING LABELS: Become familiar with your machine before using. Know its potential and limitations.

INSPECT THE MACHINE BEFORE EACH USE: The wheels must be clean and free of any cracks in the urethane. Clean machine and wheels with a clean damp cloth. Never use chemicals or solvents. Be sure to tighten all levers after each setting change.

SHOCK HAZARD: Use and store this machine only in a dry location. Do not use if the machine becomes wet. Wipe any water from the machine and allow to completely dry before using again.

EXTENSION CORD: Use only a 3-prong power cord. If the ground prong had been broken off, do not use. Use a power cord with the proper gauge wire for the length you are using. (See chart for proper size) An undersize cord will cause a drop in voltage and will cause overheating.

CARE OF EXTENSION CORD: Do not use a cord that is cracked or otherwise damaged. Keep cord away from moving wheels. Be sure cord on ground does not present a tripping hazard.

DO NOT TOUCH ROTATING WHEELS: Make no adjustments or move the machine until the wheels are completely stopped.

BE AWARE OF YOUR SURROUNDINGS: Stay alert at all times. Be aware of people around the machine while in use. Keep them behind you and the machine. Keep your eye on the batters box. Be sure only the batter is near the path of the ball.

ONLY TRAINED PERSONNEL TO OPERATE THIS MACHINE: Operators shall be properly instructed in the use and care of this machine. No one under 18 years of age shall use this machine.

ALWAYS USE A PROTECTOR SCREEN: Place a protector screen in front of the machine to protect the machine as well as the operator.

BATTERS MUST ALWAYS WEAR A BATTING HELMET

OPERATOR MUST WEAR SAFETY GLASSES Debris on the wheel could be projected and cause injury.

DO NOT POWER WITH A GASOLINE GENERATOR INDOORS Harmful fumes can cause illness or death.

NOTE: Never place any part of your body on or near any part of the pitching wheel or in front of the machine while it is in operation and/or connected to a power source. Before each use, check the pitching wheel for tightness. Tighten with an allen wrench.



MAINTENANCE

Check your machine before each use. Make sure all bolts and handles are tight.

Check the wheels for cracks or excessive wear. Make sure the screw that holds the wheels to the axle is tight.

Keep machine clean

STORAGE

Always store the machine in a clean, dry area.

Cover the machine when not in use. (CAUTION: Do not use a plastic cover. Plastic will retain moisture and will cause damage to your machine.) This will keep the machine clean and will protect the wheels from the elements. Wheels should never be left in the sunlight for prolonged periods of time. This can cause the material to deteriorate.

Enjoy your Mound Yeti !

For more information, call us at 1-800-463-6865.